

Model 8AP

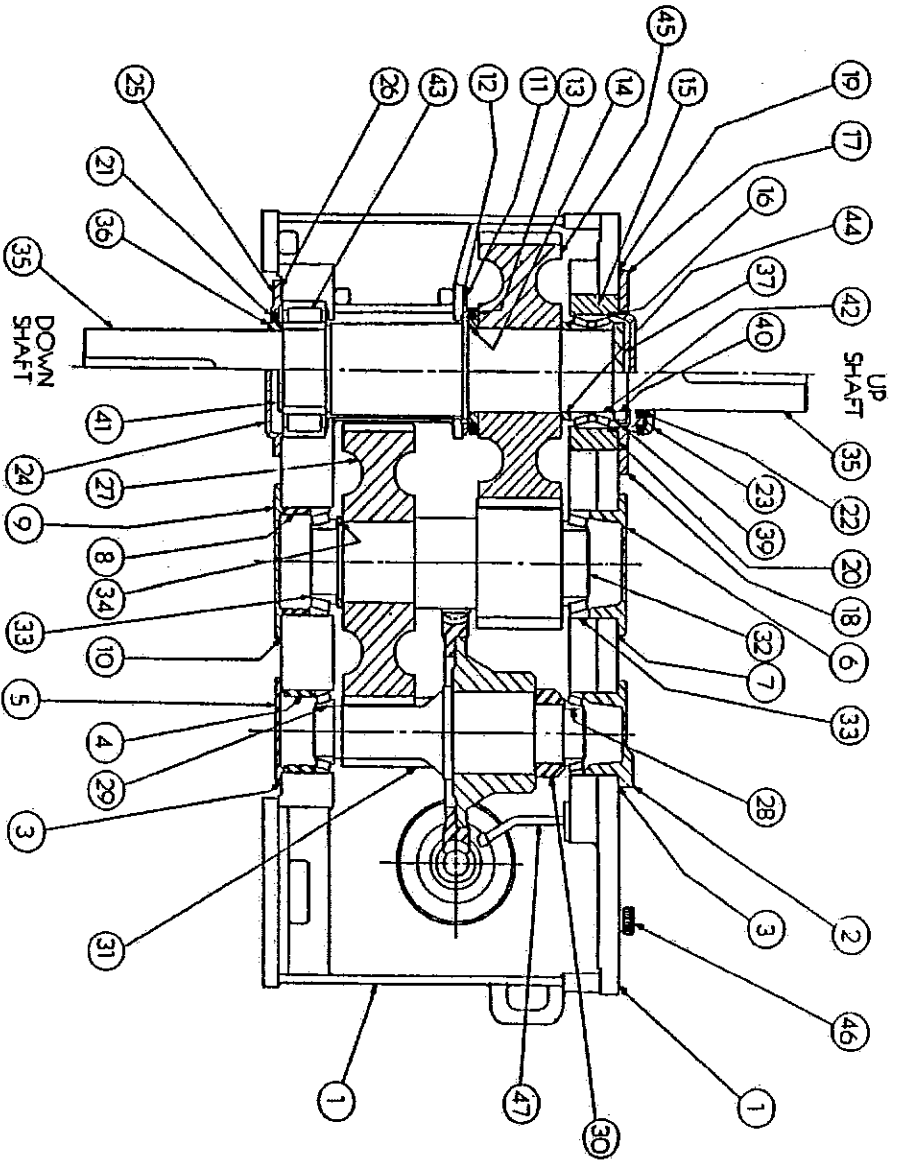

Saved as ABB-8AP 1 of 4
layout.doc

Penn Machine Company / Rail Trans Division

310 Innovation Drive
Blairsville, PA 15717
Ph 724-459-0302 Fax 724-459-0305
Emergency & After Hours 724-309-4185

Parts Guide

For
Air Preheater
Model 8AP

Ref. No.	Part Number	Description
1		Housing Base & Cover
2	250477	1 st Int. End Cover - Upper
3.1	199890	1 st Int. Upper Shim Set .007"
3.2	704835	1 st Int. Upper Shim Set .009"
3.3	704836	1 st Int. Upper Shim Set .015"
4	1130198	1 st Int. Thrust Ring-Lower
5	250479	1 st Int. End Cover - Lower
6	284037	2 nd Int. End Cover-Upper
7.1	248034	2 nd Int. Upper Shim Set .007"
7.2	704872	2 nd Int. Upper Shim Set .009"
7.3	704873	2 nd Int. Upper Shim Set .015"
8	1130197	Thrust Ring- 2 nd Int-Lower
9	235752	2 nd Int. End Cover-Lower
10.1	199893	2 nd Int. Lower Shim Set .007"
10.2	704841	2 nd Int. Lower Shim Set .009"
10.3	704842	2 nd Int. Lower Shim Set .015"
11	246282	Vapor Seal - L.S.S
12	246287	Vapor Seal Gasket
13	284172	Labyrinth Seal - L.S.S
14	927018	"O" Ring - Labyrinth Seal
15	329771	L.S. Brg. Cage - Upper
16	1130336	Thrust Ring - L.S. - Upper
17	329784	L.S. End Cover - Upper
18	329770	L.S. Seal Cage - Upper
19.1	1130343	Gasket for Upper Seal Cage or Cover .007"
19.2	710689	Gasket for Upper Seal Cage or Cover .009"
19.3	710690	Gasket for Upper Seal Cage or Cover .015"
20.1	1130345	Shim for Upper Cage or Cover .007"
20.2	710691	Shim for Upper Cage or Cover .009"
20.3	710692	Shim for Upper Seal Cage or Cover .015"

Model 8AP

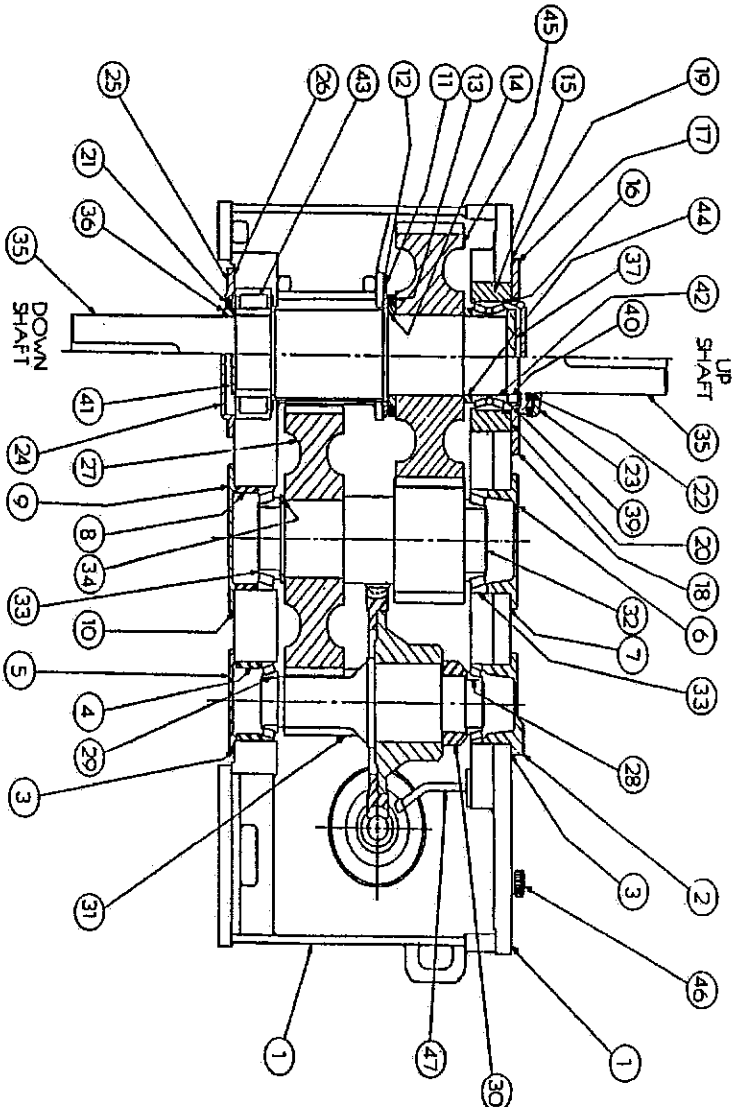

*** Sold as Set**
**** Tab's not shown on views**

Saved as ABB-8AP 2 of 4
 layout.doc

Penn Machine Company / Rail Trans Division
 310 Innovation Drive
 Blairsville, PA 15717
 Ph 724-459-0302 Fax 724-459-0305
 Emergency & After Hours 724-309-4185

Parts Guide
 For
Air Preheater
Model 8AP

21	912768	L.S. Oil Seal - Lower
22	912742	L.S. Oil Seal - Upper
23	284171	L.S. Seal Guard - Upper
24	284153	L.S. End Cover - Lower
25	329802	L.S. Seal Cage - Lower
26.1	1130342	Shim for Lower Seal Cage or Cover .007"
26.2	710687	Shim for Lower Seal Cage or Cover .009"
26.3	710688	Shim for Lower Seal Cage or Cover .015"
27.1	284118	Int. Gear - Ratio 98.32:1
27.2	284122	Int. Gear - Ratio 12.09:1
27.3	284126	Int. Gear - Ratio 139.15:1
27.4	283986	Int. Gear - Ratio 146.27:1
28	921400	Int. Pinion Brg - Upper
29	921400	Int. Pinion Brg - Lower
30	1130332	Spacer-Int. Pinion Upper Brg
31.1	284116	Int. Pinion - Ratio 98.32:1
31.2	284120	Int. Pinion - Ratio 120.09:1
31.3	284124	Int. Pinion - Ratio 139.15:1
31.4	283992	Int. Pinion - Ratio 146.27:1
32	283990	L.S. Pinion
33	921311	L.S. Pinion Brg Upper & Lower
34	1130333	Brg Spacer - L.S. Pinion Lower
35.1	329769	L.S. Shaft (Down Shaft)
35.2	329768	L.S. Shaft (Up Shaft)
36	1130335	Shrink Ring - L.S.S. Lower
37	1130339	Thrust Plate-L.S.S Upper
38		
40	905427	Locknut-L.S. Upper Brg
41	1130338	Thrust Plate-L.S.S Lower
42	921619	L.S.S Brg - Upper
43	919316	L.S.S Brg - Lower
44	1130334	Spacer-L.S.S-Upper
45	283988	L.S. Gear
46	244860	Air Vent Assy
47	244860	Spray Nozzle Assy
48**/**	336816	Worm Gear
	1130782	Fitted Bolt Assy

Model 8AP

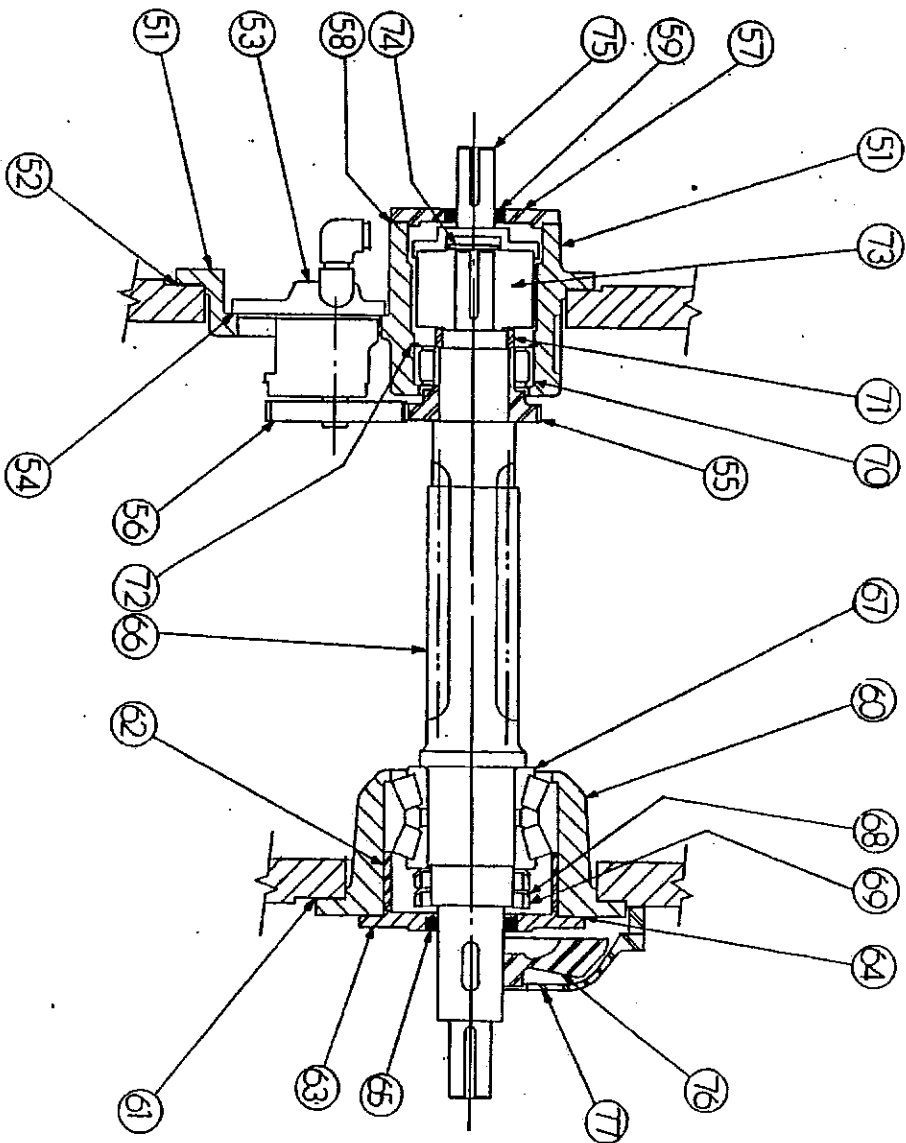

* Sold as Set
 ** Tab's not shown on views

Saved as ABB-8AP 3 of 4
 layout.doc

Penn Machine Company / Rail Trans Division

310 Innovation Drive
 Blairsville, PA 15717
 Ph 724-459-0302 Fax 724-459-0305
 Emergency & After Hours 724-309-4185

Parts Guide
 For
Air Preheater
Model 8AP

Ref. No.	Part Number	Description
	329764	Worm Gear Spider
49**	909833	Key - Worm Gear Spider
50**	909968	Key - Int. Gear
51	419132	H.S. Pump & Brg. Cage
52	1130341	H.S. Pump & Brg. Gasket
53	417550	Oil Pump
54	244608	Oil Pump Gasket
55	284056	Oil Pump Pinion
56	247090	Oil Pump Gear
57	284152	Seal Cage H.S. Aux. Side
58	1130985	Seal Cage Gasket H.S. Aux. Side
59	912749	Oil Seal H.S. Aux. Side
60	329801	H.S. Brg. Cage Main Input
61	1130340	H.S. Brg. Cage Gasket - Main Input
62	1130331	Brg. Spacer H.S. Main Input
63	284151	Seal Cage H.S. Main Input
64.1	199891	Main H.S. Seal Cage Shim Set (4) .007"
64.2	704837	Main H.S. Seal Cage Shim Set (4) .009"
64.3	704838	Main H.S. Seal Cage Shim Set (4) .015"
65	912758	Oil Seal H.S. Main Input
66	422970	H.S. Pinion - Worm
67	921618	H.S. Brg. - Main Input Side
68	906320	Lockwasher - H.S. Brg.
69	905420	Locknut - H.S. Brg.
70	919317	H.S. Brg. Aux Input Side
71	1130330	Shrink Ring H.S.S
72	917092	Snap Ring - H.S. Brg.
73	951338	Clutch
74	1130337	Thrust Plate
75	284036	Shaft Ext. 0 Aux.
76	321738	Fan
77	321743	Fan Guard
78**	1130344	Spacer - Fan
79**	909734	Key - Fan
80**	909845	Key - Clutch
81**	909601	Key - Main Input Ext.

Model 8AP

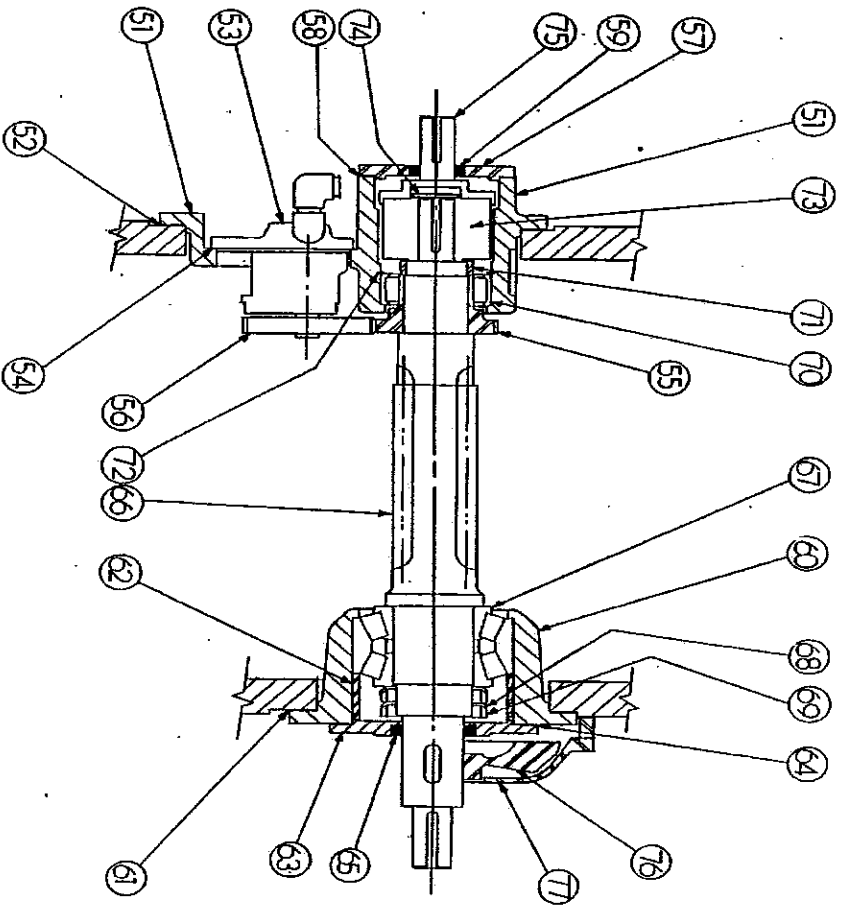

* Sold as Set
 ** Tab's not shown on views

82**	909582	Key - Aux. Input Ext.
83**	909624	Key - L.S.S. Ext
84**	909862	Key - L.S. Gear
85**	235154	Inspection Cover
86**	235158	Inspection Cover Gasket
87**	909420	Key - Pump Pinion
88**	909770	Key - Pump Gear
89**	905270	Locknut - Pump Gear
90**		Shim Set - 1 st Int. End
		Cover - Lower
91**		Complete Shim & Gasket Set
92**		Complete Shim Set
93**		Complete Gasket Set
94**	900190	Capcrew (1) - Clutch
95**	901301	Capcrew; Drilled Hd. (6) Clutch
96**	925141	Locking Wire - Clutch
97**	900935	Cap screws, Drilled Hd. (3) - L.S.S.

Saved as ABB-8AP 4 of 4 layout.doc

Penn Machine Company / Rail Trans Division
 310 Innovation Drive
 Blairsville, PA 15717
 Ph 724-459-0302 Fax 724-459-0305
 Emergency & After Hours 724-309-4185

Parts Guide
 For
Air Preheater
Model 8AP